

**PROFESSIONAL SOLAR
POWER SOLUTION
PROVIDER**

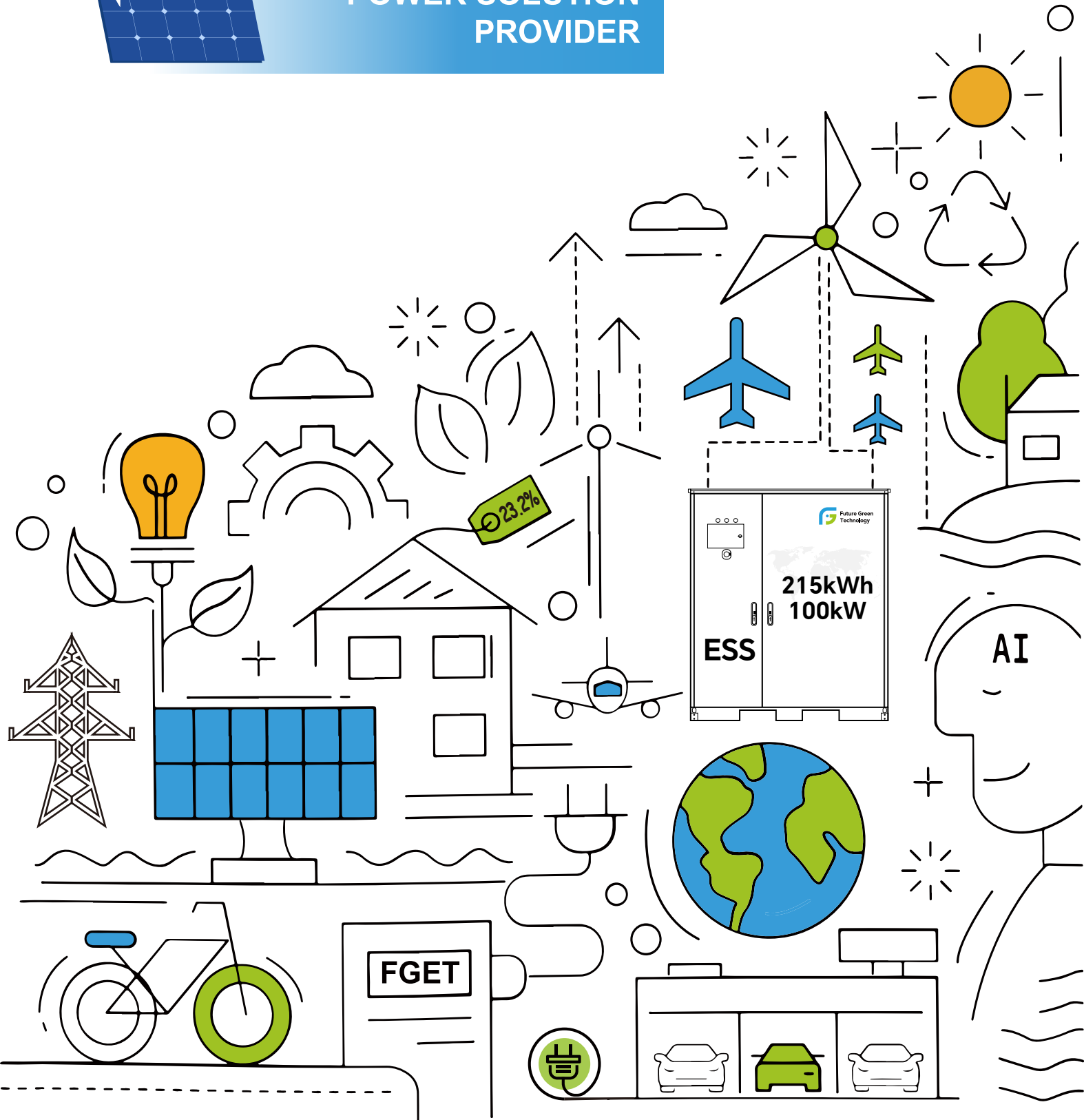



Mission: For a Green Future

At Future Green Technology, our vision is to lead the world towards a greener, more sustainable future through innovative solar energy and battery solutions. We believe in the power of renewable energy to transform our planet, reduce our carbon footprint, and foster a healthier environment for future generations. Our commitment to this vision drives every aspect of our operations, from product development to customer service.



Values: Customer-centered; striver-oriented!

We place our customers at the heart of everything we do. Understanding their needs and exceeding their expectations is our top priority. We are dedicated to providing tailored, efficient, and reliable clean energy solutions that not only meet but surpass our customers' requirements.

Our team is our greatest asset. We cultivate a culture of innovation, excellence, and continuous improvement. We empower our employees, whom we consider to be striver, to take initiative, embrace challenges, and drive our vision forward. Their dedication and hard work are the cornerstones of our success.

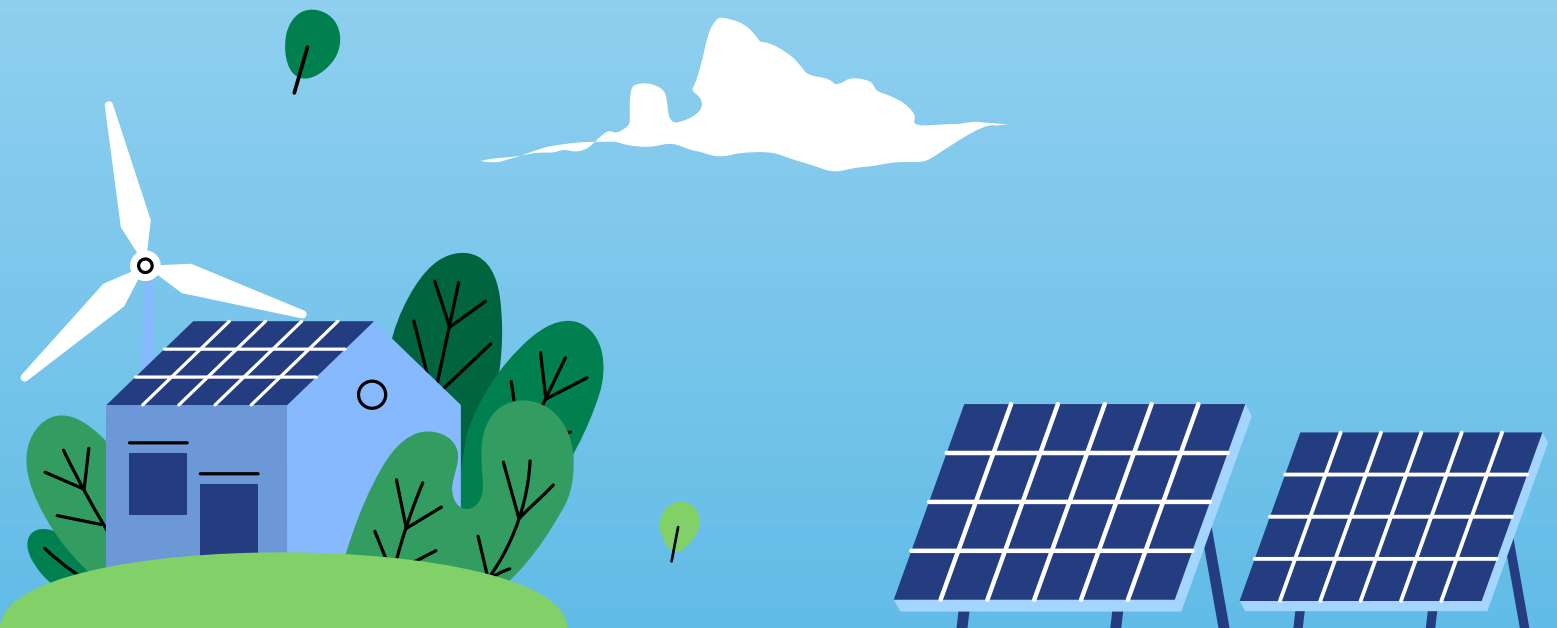

CONTENTS

Company Introduction	01
Product Introduction	03
Solar Panel	03-08
Lead-Acid Battery	09-16
LiFePO ₄ Battery	17-20
Energy Storage System	21-24
Solar Light	25-27
Solar Power System	28-33
Certifications	34
Project Cases	35
Partners	36





Future Green Technology Co., Ltd.

2

Factories

107+

countries and regions

1_{GW}

Annual output

25_{Years}

Experience



Located in Guangzhou, China, Future Green Technology is at the forefront of solar power and battery solutions, with two advanced factories dedicated to bringing clean energy to the globe.

Our Offerings:

- › High-Efficiency Solar Panels: Crafted with the latest technology for peak performance.
- › Batteries: Reliable and sustainable power storage and motive solutions.
- › Comprehensive Solar Systems: Tailored solutions for both homes and businesses, ensuring reliable and eco-friendly energy.
- › Customization & Branding: Personalized solar solutions and product branding to meet your unique needs.

Partner with Us:

Join our network of distributors and agents to be part of the clean energy revolution. We offer exceptional support and opportunities for growth in the renewable energy sector.

Our Commitment:





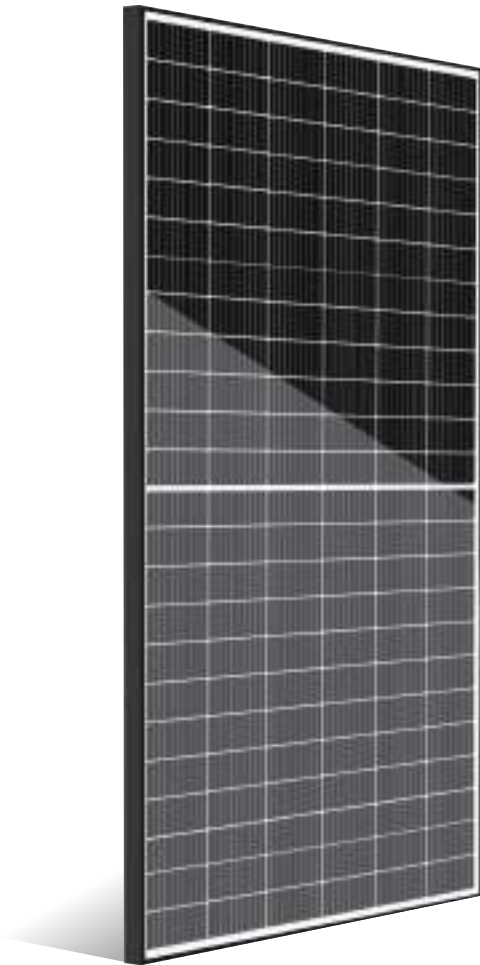

At Future Green Technology, we are more than just a company; we are a movement towards a brighter, greener future. Join us in our journey to power the world with clean, sustainable energy.

M10 Solar Panel

420W-640W



» PRODUCT SPECIALTY

-  Lower LID
-  182mm N-Type Solar Cell
-  Higher Efficiency
-  Lower Temperature Coefficient
-  Mature N-Type Manufacturing
-  Balance of Size & Handling
-  Established Supply Chain
-  Lower Current

15 15 Year materials and workmanship warranty | **25** 25 Year linear power output warranty

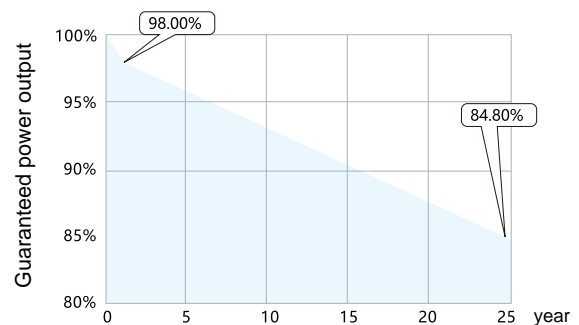







Product Model	Pm(W)	Module Size(mm)	Vm(V)	Im(A)	Voc(V)	Isc(A)	Package	Cells	Remark
M10-620-640N	640	2465*1134*30	46.57	13.74	55.88	14.43	36PCS/Pallet	M10/156HC	Bifacial Monofacial White Black
M10-570-590N	590	2278*1134*30	43.00	13.72	51.60	14.41	36PCS/Pallet	M10/144HC	
M10-520-540N	540	2094*1134*30	40.03	13.49	48.04	14.16	36PCS/Pallet	M10/132HC	
M10-470-490N	490	1909*1134*30	36.06	13.59	43.27	14.27	36PCS/Pallet	M10/120HC	
M10-420-440N	440	1724*1134*30	32.45	13.56	38.94	14.24	36PCS/Pallet	M10/108HC	

G12 Solar Panel

435W-720W



» PRODUCT SPECIALTY

-  210mm*210mm Solar Cell
-  210mm*182mm Rectangular Solar Cell
-  Optimized for Container Utilization
-  Higher Power Output per Panel
-  Fewer Interconnects
-  Balance of Size & Handling
-  Growing Market Adoption
-  Weak-Light Performance

15 15 Year materials and workmanship warranty | **25** 25 Year linear power output warranty

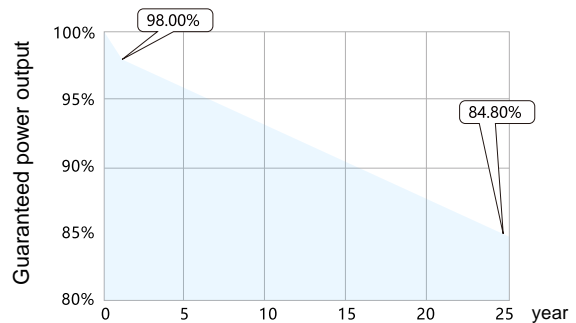

Product Model	Pm(W)	Module Size(mm)	Vm(V)	Im(A)	Voc(V)	Isc(A)	Package	Cells	Remark
G12-695-720N	720	2384*1303*33	41.30	17.43	49.56	18.30	33PCS/Pallet	G12/132HC	Bifacial Monofacial White Black
G12-620-640N	640	2172*1303*30	37.12	17.24	44.54	18.10	36PCS/Pallet	G12/120HC	
G12R-605-620N	625	2382*1134*30	41.39	15.10	49.67	15.86	36PCS/Pallet	G12R/132HC	
G12R-490-510N	510	1961*1134*30	33.91	15.04	40.69	15.79	36PCS/Pallet	G12R/108HC	
G12R-435-455N	455	1762*1134*30	30.21	15.06	36.25	15.81	36PCS/Pallet	G12R/96HC	





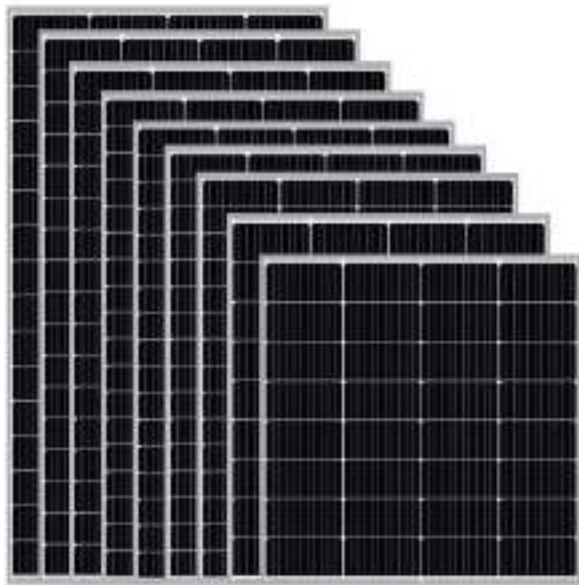



Customized Solar Panel

182mm Solar Cell



Customize the power you want

» PRODUCT SPECIALTY

-  No MOQ
-  Flexible Customization
-  Power & Size Adaptability
-  Voltage & Connector Options
-  Lightweight & Portable Design
-  Rapid Prototyping & Delivery
-  Integrated Smart Features
-  End-to-End Support

15 15 Year materials and workmanship warranty

25 25 Year linear power output warranty

Product model	Pm(W)	Module Size(mm)	Surface	Vm(V)	Im(A)	Voc(V)	Isc(A)	Weight	Package
M10-300N	300	1290*1134*30	Glass	34	8.80	42.10	9.60	16.10	2Pcs/Ctn
M10-240N	240	1515*780*30	Glass	18	13.30	22.30	14.50	13.00	2Pcs/Ctn
M10-200N	200	1290*780*30	Glass	21	9.50	26.00	10.40	11.10	2Pcs/Ctn
M10-180N	180	1150*780*30	Glass	18	10.00	22.30	10.90	9.90	2Pcs/Ctn
M10-160N	160	1025*760*30	Glass	18	8.90	22.30	9.70	8.60	2Pcs/Ctn
M10-120N	120	1070*585*30	Glass	18	6.70	22.30	7.30	6.90	2Pcs/Ctn
M10-110N	110	970*580*30	Glass	18	6.40	21.30	7.00	6.20	2Pcs/Ctn
M10-80N	80	760*540*25	Glass	18	4.40	22.30	4.80	4.50	2Pcs/Ctn
M10-60N	60	780*420*25	Glass	18	3.30	22.30	3.60	3.60	2Pcs/Ctn
M10-50N	50	660*400*25	Glass	18	2.80	22.30	3.00	2.90	2Pcs/Ctn
M10-40N	40	560*398*25	Glass	18	2.20	22.30	2.40	2.50	2Pcs/Ctn









Customized Solar Panel

210mm Solar Cell



Customize the power you want

» PRODUCT SPECIALTY

-  High Power Output
-  Dual-Glass Durability
-  Sleek Aesthetic Design
-  Lightweight & Portable
-  Low-Light Efficiency
-  Smart Compatibility
-  Weather Resilience
-  Totally Customization

15 15 Year materials and workmanship warranty

25 25 Year linear power output warranty

Product model	Pm(W)	Module Size(mm)	Surface	Vm(V)	Im(A)	Voc(V)	Isc(A)	Weight	Package
G12-200N	200	1320*670*30	Bifacial	18	11.11	21.96	11.67	9.70	2Pcs/Ctn
G12-150N	150	1110*670*30	Bifacial	18	8.33	21.96	8.75	8.20	2Pcs/Ctn
G12-100N	100	1120*450*30	Bifacial	18	5.56	21.96	5.83	5.50	2Pcs/Ctn
G12-350N	350	1515*1000*30	Glass	36	9.72	43.92	10.21	16.70	2Pcs/Ctn
G12-250N	250	1110*1090*30	Glass	30	8.33	36.60	8.75	13.30	2Pcs/Ctn
G12-200N	200	1320*670*30	Glass	18	11.11	21.96	11.67	9.70	2Pcs/Ctn
G12-150N	150	1110*670*30	Glass	18	8.33	21.96	8.75	8.20	2Pcs/Ctn
G12-135N	135	1300*510*30	Glass	18	7.50	21.96	7.88	7.30	2Pcs/Ctn
G12-100N	100	1120*450*30	Glass	18	5.56	21.96	5.83	5.50	2Pcs/Ctn
G12-80N	80	910*450*30	Glass	18	4.44	21.96	4.67	4.50	2Pcs/Ctn
G12-50N	50	590*450*25	Glass	18	2.78	21.96	2.92	2.90	2Pcs/Ctn
G12-40N	40	465*450*25	Glass	18	2.22	21.96	2.33	2.30	2Pcs/Ctn









Flexible Solar Panel

10W-300W



PET & ETFE Optional

» PRODUCT SPECIALTY

-  Conformability
-  Bendable
-  Lightweight
-  Easy Installation
-  Customizable
-  Durable & Weatherproof
-  Portable Options
-  Mobile & Off-Grid Focus

2 2 Year materials and workmanship warranty

5 5 Year linear power output warranty

Product model	Pm(W)	Module Size(mm)	Surface	Vm(V)	Im(A)	Voc(V)	Isc(A)	Weight	Package
M10-300FL	300	1530*990*3	ETFE/PET	36	8.33	23.30	3.47	5.30	2Pcs/Ctn
M10-240FL	250	1530*780*3	ETFE/PET	36	6.94	23.30	3.47	4.20	2Pcs/Ctn
M10-200FL	200	1290*800*3	ETFE/PET	18	11.11	23.30	3.47	3.60	2Pcs/Ctn
M10-150FL	150	1050*780*3	ETFE/PET	18	8.33	23.30	3.47	2.90	2Pcs/Ctn
M10-120FL	120	900*780*3	ETFE/PET	18	6.67	23.30	3.47	2.50	2Pcs/Ctn
M10-110FL	110	1000*600*3	ETFE/PET	18	6.11	23.30	3.47	2.10	2Pcs/Ctn
M10-80FL	80	750*600*3	ETFE/PET	18	4.44	23.30	3.47	1.60	2Pcs/Ctn
M10-80FL	75	1060*410*3	ETFE/PET	18	4.17	23.30	3.47	1.50	2Pcs/Ctn
M10-50FL	50	585*410*3	ETFE/PET	18	2.78	21.96	2.92	0.80	2Pcs/Ctn
G12-200FL	200	1330*680*3	ETFE/PET	18	11.11	21.96	11.67	3.20	2Pcs/Ctn
G12-150FL	150	1120*680*3	ETFE/PET	18	8.33	21.96	8.75	2.70	2Pcs/Ctn
G12-100FL	100	1120*460*3	ETFE/PET	18	5.56	21.96	5.83	1.80	2Pcs/Ctn
G12-50FL	50	600*460*3	ETFE/PET	18	2.78	21.96	2.92	1.00	2Pcs/Ctn

Portable Solar Panel

50W-400W



» PRODUCT SPECIALTY

-  High Portability
-  Mobile & Off-Grid Focus
-  All-in-One Solution
-  Ideal for Off-Grid Use
-  Quick and Easy Setup
-  Environmentally Friendly
-  Various Power Outputs
-  Charge Multiple Devices



Product Model	FL-50F2	FL-100F2	FL-200F4	FL-400F4
Peak Power	50W	100W	200W	400W
Maximum Power Point Voltage	19.42V	23.82V	19.59V	40V
Maximum Power Point Current	2.57A	4.2A	10.21A	10A
Open Circuit Voltage(Voc)	24.01V	23.98V	23.57V	49.8V
Short Circuit Current(Isc)	2.70A	5.5A	11.14A	10.88A
Connector Type	DC Multiple Outputs	DC Multiple Outputs	Standard MC4	Standard MC4
IP Class	IP67	IP67	IP67	IP67
Operating Temperature	-10 ~ 65°C	-10 ~ 65°C	-10 ~ 65°C	-10 ~ 65°C
Weight	9.9lbs. (4.5Kg)	11.5lbs. (5.2Kg)	18.5 lbs. (8.6 Kg)	31.2 lbs. (14.15 kg)
Folded Dimensions (mm)	540x390x51	570x590x51	640x540x79	570x1070x61
Unfolded Dimensions (mm)	780x540x33	1150x590x30	2380x540x36	2310x1070x23



Valve-Regulated Gel Battery

Storage battery Series(Application)
Solar system / Safety system / Wind power system



Summary

The G-FM series is a floating-charge universal battery with a design life of 5 years. It complies with IEC standards. Using the latest AGM value to control technology and high purity, the original GFM series is suitable for UPS/EPS, medical devices, solar system and wind power system. The G-FM series maintains high consistency for better performance and more reliable standby life.

Product Features

- > Capacity Range: 50Ah-250Ah;
- > Voltage: 12V;
- > Long Lifespan (25°C): 5 years;
- > Low Self-discharge Rate: $\leq 3\%$ / month;
- > High Rate Discharge Performance;
- > High Sealing Reaction Efficiency: $\geq 99\%$;
- > Wide Operating Temperature: $-20^{\circ}\text{C} - 60^{\circ}\text{C}$;
- > Structure: Compact design, Shorter internal connection between batteries (hence lower internal resistance);
- > Plate: Paste type;
- > Terminal: Provides more terminal type options;
- > Diaphragm: Improved AGM diaphragm for lower internal resistance and higher assembly pressure to improve cycle life;
- > Battery Box: High-strength ABS (UL94-HB) or UL94-V0;
- > Terminal Seal: Double seal technology (mechanical + epoxy resin adhesive).

Designation Of Battery Type Numbers

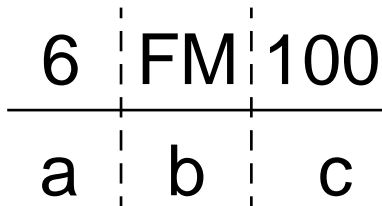

Designations:

a - quantity of cells

b - valve-regulated

c - battery capacity at 20 hour rate

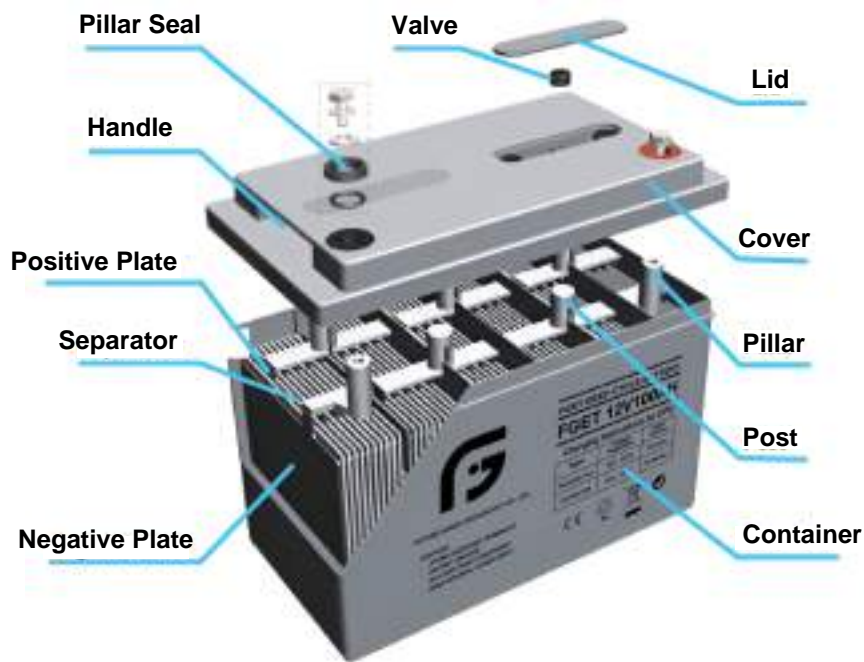

Model	Voltage	Capacity C20	Dimensions				Approx. Weight	Terminal Type
			Length	Width	Height	Total height		
	(v)	(Ah)	mm	mm	mm	mm	Kg	
GLE6FM33	12	33	196	131	155	180	10.2	M6
GLE6FM40	12	40	196	165	175	175	12	M6
GLE6FM55	12	55	229	138	208	227	16.5	M6
GLE6FM65	12	65	350	166	175	175	20.5	M8
GLE6FM75	12	75	260	169	208	227	21.5	M8
GLE6FM90	12	90	307	168	208	227	25	M8
GLE6FM100	12	100	328	172	222	222	29.5	M8
GLE6FM120	12	120	406	174	208	233	33	M8
GLE6FM150	12	150	483	170	241	241	43	M8
GLE6FM200	12	200	522	240	219	244	59	M8
GLE6FM260	12	260	522	268	219	228	69	M8



Valve-Regulated Lead-Acid Battery

UPS battery Series (Application)
Emergency light / Safety system / Toy / Medical device



Summary

The FM series is a floating-charge universal battery with a design life of 5 years.

It complies with IEC standards and uses the latest AGM value to control technology and high purity raw materials, and the battery has a reliable standby life.

The FM series is suitable for UPS/EPS, medical devices, emergency lights and security systems.

Product Features

- > Capacity Range: 2.6Ah-80Ah;
- > Voltage : 6V/12V;
- > Long Lifespan (25°C): 5 years;
- > Low Self-discharge Rate : $\leq 3\%$ / month;
- > High Rate Discharge Performance;
- > High Sealing Reaction Efficiency : $\geq 99\%$;
- > Wide Operating Temperature : $-20^{\circ}\text{C} - 60^{\circ}\text{C}$;
- > Structure: Compact design, Shorter internal connection between batteries (hence lower internal resistance);
- > Plate: Paste type;
- > Terminal: Provides more types of terminal to options;
- > Diaphragm: Improved AGM diaphragm for lower internal resistance and higher assembly pressure to improve cycle life;
- > Battery Box: High-strength ABS (UL94-HB) or UL94-V0;
- > Terminal Seal: Double seal technology (mechanical + epoxy resin adhesive).

VRLA Battery Series

Model	Voltage (v)	Capacity C20 (Ah)	Dimensions				Approx. Weight Kg	Terminal Type
			Length mm	Width mm	Height mm	Total Height mm		
6FM1.3	12	1.3	97	43	51	57	0.6	F1/F2
6FM2.6	12	2.6	70	47	99	105	0.8	F1/F2
6FM3.2	12	3.2	134	67	61	67	1.2	F1/F2
6FM4.2	12	4.2	90	70	101	107	1.4	F1/F2
6FM4.5	12	4.5	90	70	101	107	1.5	F1/F2
6FM5	12	5	151	65	94	100	1.8	F1/F2
6FM7	12	7	151	65	94	100	2.1	F1/F2
6FM7.2	12	7.2	151	65	94	100	2.2	F1/F2
6FM9	12	9	151	65	94	100	2.6	F1/F2
6FM12	12	12	151	98	95	101	3.7	F2
6FM17	12	17	181	77	167	167	4.9	M5
6FM20	12	20	181	77	167	167	6	M5
6FM24	12	24	177	165	126	126	8.7	M5
6FM28	12	28	177	165	126	126	8.3	M5
6FM33	12	33	196	131	155	180	10.2	M6
6FM38	12	38	196	165	175	182	11.4	M6
6FM55	12	55	229	138	208	227	16.5	M6
6FM65	12	65	350	166	175	175	20.5	M8
6FM75	12	75	260	169	208	227	21.5	M8
6FM90	12	90	307	168	208	227	25	M8
6FM100	12	100	328	172	222	222	29.5	M8
6FM120	12	120	406	174	208	233	33	M8
6FM150	12	150	483	170	241	241	43	M8
6FM180	12	180	532	207	215	240	52	M8
6FM200	12	200	522	240	219	244	59	M8
6FM260	12	260	522	268	219	228	69	M8

Application & Production





AGM BATTERY FRONT TERMINAL VRLA BATTERY

Designed floating service life: 12 years @20 °C/68 °F
Voltage covers: 12V
Capacity: from 50Ah to 200Ah



Main Applications

- Communication Equipment
- Fire & Security Systems
- Uninterruptible Power Supply
- Telecommunication Systems
- Control Equipment
- Geophysical Equipment
- Medical Equipment
- Emergency Power Systems



General Features

01 Long Life Time

Especially designed for telecommunication use with 10+ years design life in float service. By combining the newly developed paste formula with up-to-date AGM structures, this range features 12 years design life.

02 Front Access Connection

Front access connection for fast, easy installation and maintenance with standard width for 19' and 23' ETSI racks.

03 Valve Regulating

Perfect venting system, is designed to release excess gas and keep the internal pressure within the optimum range of efficient performance.

04 Excellent Recovery from Deep Cycle

Unique technical processes are used into the grid alloy and electrolyte additive, in this case the battery can be recharged after being over-discharged.



Model	Voltage	Capacity C20	Dimensions				Approx. Weight	Terminal Type
	(V)		Length	Width	Height	Total Height		
	(Ah)	mm	mm	mm	mm	Kg		
FT12V55Ah-F	12	55	277	106	222.5	222.5	17.0	M5
FT12V75Ah-F	12	75	562	114	188	188	18.0	M5
FT12V80Ah-F	12	80	562	114	188	188	26.0	M5
FT12V100Ah-F	12	100	394	110	286	286	32.0	M8
FT12V100Ah-SF	12	100	507	110	223	238	32.0	M8
FT12V105Ah-F	12	105	507	109	223	238	35.0	M8
FT12V125Ah-F	12	125	436	108	317	317	37.0	M8
FT12V140Ah-F	12	140	552	110	288	295	44.0	M8
FT12V150Ah-F	12	150	551	110	287	287	45.0	M8
FT12V160Ah-F	12	160	551	110	316	316	49.0	M8
FT12V180Ah-F	12	180	560	125	316	316	53.0	M8





DZF Series Lead Acid Long Cycle Life, Deep Discharge

FGET DZF Series Battery is specially designed for motive Power applications, i.e., electric bikes/scooters, electric tricycles, electric motorcycles, and other devices that require a DC power source.



Features & benefits

01 Non-Cadmium Design, Environment-friendly:

FGET Battery has adopted internationally leading technology - Non-Cadmium container formation Production Process technology, which is in the leading position in the industry. It helps to save energy 28.5%, save water 90%, and non-discharge of waste water.

03 Strong Motive Power:

Super thin plate design is adopted to increase the area of electrochemical reaction, which enables the battery has excellent large current discharge ability. Adopting cast-welding process to reduce the battery's internal resistance, so the battery's charge/discharge efficiency is improved to enable battery with large power discharge capability.

05 Non-Spillable and High Safety:

The battery container and lid are made of Enhanced ABS material and they are sealed by epoxy resin, so the battery is well sealed without any acid leakage issue. High accuracy safety valve has been applied to prevent battery bulging, and safety valve and acid filter are used for preventing sparks splashed into battery to ensure the safety use of battery.

02 Super Long Mileage:

Special active additives have been added in the positive plate to improve the consistency of the formed active material after formation. This has been obviously improved the battery's charge/discharge efficiency, and more power can be released during discharging. The mileage of each discharge is improved significantly.

04 Super Long Mileage:

The FGET battery has excellent cycle life which can reach 600 cycles @ 80% DOD. The batteries are well grouped to improve the battery bank's consistency in order to improve the battery bank's service life.

06 High Reliability:

Improved negative material prescription and increased micropole structure at negative helps to improve a lot on charge/discharge performance at extreme temperature condition. Low water loss rate, high temperature resistance, and battery deformation resistance.



Model	Nominal	Capacity C3/C2	Dimensions				Approx. Weight	Terminals
			Length	Width	Height	Total Height		
	(v)	(Ah)	mm	mm	mm	mm	Kg	
6-DZF-12	12	12	151	99	98	98.5	4.1	M5
6-DZF-12.3	12	12.3	151	99	98	98.5	3.95	M5
6-DZF-13.3	12	13.3	151	99	98	98.5	4.35	M5
6-DZF-20.3	12	20.3	181	77	170	170	6.15	M5
6-DZF-20.9	12	20.9	181	77	170	170	6.35	M5
6-DZF-22	12	22	181	77	170	170	6.5	M5
6-DZF-23	12	23	181	77	170	170	6.85	M5
6-DZF-24	12	24	181	77	170	170	7	M5
6-DZF-36.3	12	36.3	267	77	170	170	10	M5
8-DZF-14	16	14	201	113	100	100	6.25	M5
8-DZF-20	16	20	250	100	126	126	9.3	M5
6-DZF-32	12	32	220	92	175	175	9.6	M5
6-DZF-45/48	12	45	222	120	178	178	12.8	M5
6-DZF-52	12	52	222	130	177	177	14.3	M5
6-DZF-55	12	55	222	155	175	175	15.7	M5





Lead Acid Replacement LiFePO₄ Battery

LiFePO₄ batteries in Lead-Acid Batteries case are often designed to replace traditional lead-acid batteries in many applications.



Features & benefits

01 High Energy Density:

Stores 4x more energy per unit volume than lead-acid batteries.
Supports deep discharge (up to 90% DOD) without capacity loss.

03 High Power Output:

Delivers 4x higher continuous power than SLA batteries.
Maintains stable voltage under heavy loads (e.g., EVs, solar storage).

05 Light weight Design:

70% lighter than equivalent lead-acid batteries.
Compact size enables flexible installation (e.g., RVs, marine).

02 Eco-Friendly:

Made from non-toxic, abundant iron phosphate (no heavy metals).
30% lower carbon footprint in production; 95% recyclable.

04 Long Service Life:

2,500+ full charge/discharge cycles (≥10 years at 80% capacity retention).
Minimal self-discharge (<3% per month).

06 Seamless Drop-in Replacement:

LiFePO₄ batteries in Lead-Acid Batteries case are often designed to replace traditional lead-acid batteries in many applications. This means they can perfectly fit into existing systems without requiring modifications to the circuit, simplifying installation and eliminating the need for additional accessories.

Designation Of Battery Type Numbers

Model	FGLFP-12100	FGLFP-12150	FGLFP-12200	FGLFP-24150
Configuration	1P4S	1P4S	2P4S	1P8S
Working Voltage(V)	11V~14.6V	11V~14.6V	11V~14.6V	22V~29.2V
Nominal Capacity (Ah)	100Ah	150Ah	200Ah	150Ah
Ratedenergy(Wh)	1280Wh	1920Wh	2560Wh	3840Wh
Charge/discharge Current(A)	50A @25±2°C	50A @25±2°C	50A @25±2°C	50A @25±2°C
Maximum discharge current	100A @25±2°C	100A @25±2°C	150A @25±2°C	150A @25±2°C
Display	LED Capacity Indicator			
Working Temperature	0~40°C(Charge)-10~40°C(Discharge)			
Storage temperature and humidity	-10°C~35°C (Within one month of storage) 25±2°C (Within three months of storage) 65%±20%RH			
Number of parallel machines	10	10	10	10
Dimension(mm)	260*170*214mm	330*172*215mm	501*182*242mm	522*240*224mm
Weight	10KG	13KG	19KG	37.5KG
Cycle life	5000 cycles @25°C 50A charge and discharge current 75% DOD			
Altitude Limited(m)	0-3000m			
Humidity(%)	5~80%			
Outer packaging size(mm)	280*185*230mm	340*185*230mm	510*195*260mm	540*260*250mm



48V LiFePO₄ battery

48V/51.2V LiFePO₄ battery, high energy density, stylish appearance, easy to install and expand, widely used in telecom base stations, commercial energy storage, UPS, residential energy storage systems.



Features & benefits



Light weight, small size



Support a variety of communication protocols, support RS485, RS232, CAN etc.



Long cycle life, using high-quality LiFePO₄ Cells, the cycle life is as high as 6000 times



Compatible with a variety of inverters



Intelligent battery management system



In the extreme performance safety test, the battery will not catch fire, explode, leak, and be safer to use.

Basic Parameter	HL-PW48100A	HL-PW48200A	HL-PW48300A
Nominal Voltage	48/51.2V	48/51.2V	48/51.2V
Nominal Capacity	100Ah	200Ah	300Ah
Energy	4800/5120Wh	9600/10240Wh	14400/15360Wh
Dimension	560x490x155mm	700x460x170mm	840x330x755mm
Weight	49.6Kg	74Kg	138Kg
Discharge Cut-off Voltage	40.5(15S)/43.2(16S)	40.5(15S)/43.2(16S)	37.5(15S)/40(16S)
Charge Cut-off Voltage	54.7(15S)/58.4(16S)	54.7(15S)/58.4(16S)	54.75(15S)/58.4(16S)
Communication Port	RS485,RS232 CAN		
Cell serial number	15 PCS /16 PCS		
Working Temperature/°C	-10~60°C	-10~60°C	-10~60°C
Design life	10+Years (25° C/77° F)		
Cycle Life	>6000, 25° C/77° F, 80%DOD		
Certification	CE/UN38.3		
Maximum number of parallel connections	16	16	16
Maximum continuous charge current	100A	100A	100A
Maximum continuous discharge current	100A	100A	200A





Energy Storage System

ESS utilizes high-voltage stackable all in one energy storage system, featuring modular high-voltage battery, integrated photovoltaic inverter modules, a complete set of energy storage solutions, no installation required, suitable for residential or commercial energy storage.



Features & benefits



Safe and reliable, IP54/IP20 protection level, Integrated fire protection and Air-conditioner



Support RS485/WiFi communication protocol



Integrated BMS/PCS/EMS



Modular design, easy to install and disassemble, free to add, strong availability



LED panel display the parameters of the equipment in real time



Efficient Space Utilization



Model	50kWh+30kW/IP54	100kWh-50kW	215kWh-100kW
Battery			
Battery type	LiFePO ₄		
Rated Energy	51kWh	100kWh	215kWh
Nominal Voltage	512V	512V	768V
Number of Slaver Module	9	9	14
Rated Capacity	100Ah	200Ah	280Ah
Max. Discharge Current	100A	200A	200A
Max. Charge Current	100A	200A	200A
PV			
Max. power	38kW	50kW	100kW
Max. PV Voltage	850Vdc	1000Vdc	1000Vdc
MPPT Voltage Range	200~820Vdc	300~850Vdc	150~650Vdc
Max. PV Current	30A+30A	35A+35A+35A	100A+100A
MPPT String	2	3	2
On-Grid			
Rated Power	30kW	50kW	100kW
Rated Voltage	400Vac/230Vac (L1/L2/L3/N/PE)		
Rated Frequency	50Hz/60Hz		
Max. AC Current		75A	
THDi	<3%		
Off-grid			
Rated Power	30kW	50kW	100kW
Rated Voltage	400Vac/230Vac (L1/L2/L3/N/PE)		
Rated Frequency	50Hz/60Hz		
Max. AC Current	43A	75A	145A
Max. Parallel number	5	5	5
General Parameter			
Communication	RS485/WiFi		
IP Class	IP54		
Operating temperature	-15~55°C		
Humidity range	5%~95%		
Altitude	<3000m		
Fire Protection	Aerosol and Perfluorohexanone		
Cooling Mode	Air-Conditioner		
PCS cooling method	Intelligent cooling		
Size	680*950*1450mm	1100*1000*1850mm	1450*1100*2050mm
Weight	600kg(Approx)	1400kg(Approx)	2400kg(Approx)



All-in-one Solar System

All-in-one Solar System combines PV panels, energy storage systems, and inverters. Key features include integrated design, flexible configuration, and smart management, which can provide clean, stable energy for homes, urban residents, and even remote areas, while reducing electricity costs.



Lithium Battery+Inverter



Integrated UPS Function



Integrated PV and Mains Charging



High Integration and Easy Installation

Model	5.12kWh+5kW	10kWh+5kW	10kWh+10kW	14.3/15/16kWh+12kW
Standard Voltage	51.2V	51.2V	51.2V	51.2V
Rated Capacity	100Ah	200Ah	200Ah	280/300/314Ah
Battery Power	5.12kWh	10.24kWh	10.24kWh	14.3/15/16kWh
Inverter Power	5kW	5kW	10kW	12kW
MPPT Voltage Range	120~430Vdc	120~430Vdc	90~450Vdc	90~450Vdc
IP Class	IP20	IP20	IP20	IP20
Communication Mode	RS485/WiFi	RS485/WiFi	RS485/WiFi	RS485/WiFi
Size(mm)	450*270*610mm	485*270*760mm	505*306*820mm	510*377*770mm
Weight(kg)	51kg(Approx)	88kg(Approx)	105kg(Approx)	120kg(Approx)
Available Styles	Wall-mounted, Standing, Stackable.			



All-DC Integrated PV-Storage -Charging Cabinet

All-DC Integrated PV-Storage-Charging Cabinet is an intelligent power equipment that integrates the three core functions of photovoltaic power generation, energy storage and DC charging, and realizes efficient energy flow through a full DC link.



GB/EU/US/Japanese Charging Protocol

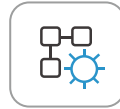

Integrated Energy Storage/PV/ Charging Modules



PV-Storage-Charging DC-Coupled System



Support DC/AC/PV Charging Supplement

Model	32kWh+15kW	60kWh+60kW	122kWh+120kW	153kWh+120kW	209kWh+120kW (Air/Liquid Cooling)
Lithium-ion Battery	32kWh	60kWh	122kWh	153kWh	209kWh
Fast Charging Power	15kW	60kW	120kW	120kW	120kW
Max DC Input Power	/	30kW	80kW	80kW	100kW
Max AC Input Power	15kW	30kW	30kW	30kW	30kW
Max PV Input Power	15kW	35kW	35kW	35kW	35kW
IP Class	IP54	IP54	IP54	IP54	IP54
Communication Mode	RS485(WiFi/4G optional)				
Size(mm)	680*1000*1200mm	680*1000*1450mm	1200*1000*1450mm	1200*1000*1750mm	1600*1000*2050mm 1300*1200*1600mm
Weight(kg)	500kg(Approx)	850kg(Approx)	1400kg(Approx)	1650kg(Approx)	1600kg(Approx)

Solar Flood Light

- > Smart Operation:
180°Human body sensing, intelligent controller.
- > Practical Function:
Improve nighttime convenience, strong adaptability of lighting range.
- > New Upgrade:
High-lumen LEDs, low energy consumption and long life.
- > Enhance Security:
Convenient for observing surrounding conditions.
- > Light Source Style Optional:
Three-layer reflector cup design and lamp beads.



Solar charger



Light control



Waterproof and lightning protection



Strong battery life



Smart remote

Product Specification

Model	TS-200W PRO/MAX	TS-400W PRO/MAX	TS-600W PRO/MAX	TS-800W PRO/MAX
Luminous Flux	1500LM	3000LM	4500LM	6000LM
Solar Panel	20W	40W	50W	65W
Battery Capacity	3.2V15000mAh	3.2V30000mAh	3.2V45000mAh	3.2V60000mAh
Lamp Size	282*225*65mm	342*279*65mm	386*315*65mm	386*315*65mm
Panel Size	295*395*17mm	530*395*17mm	590*395*17mm	770*395*17mm
Package	8sets/CTN	6sets/CTN	5sets/CTN	5sets/CTN
Carton Size	503*355*247mm	580*365*287mm	453*355*347mm	453*355*347mm
Led Chips	144pcs LED Chips	296pcs LED Chips	432pcs LED Chips	432pcs LED Chips
IP Class	IP66			
Charging Time	4-5h			
Working Time	12-24h			
Color Temperature	Cool White (6000-6500K)			

All-in-one Solar Light

- > **Solar-Powered, Cost-Free Illumination:**
Embrace sustainable energy with solar power – no more electricity bills!
- > **Smart Operation:**
Automatically turns on at dusk and off at dawn.
- > **Enhanced Brightness:**
Optical lens technology boosts light efficiency by 20%.
- > **Personalized Definition:**
Choose from a range of decorative panel colors to complement your surroundings.
- > **Brilliant Illumination:**
High-lumen LEDs deliver powerful, clear light.



Solar charger



Light control



Waterproof and lightning protection



Strong battery life



Smart remote

Customizable colors

You can customize the color you like



Orange/White



Blue/White



Purple/White



Orange/Gray



Blue/Gray



Red/Gray

Product Specification

Model	LA-400	LA-600	LA-800
Lumen	1200LM	1800LM	2400LM
Solar Panel	15W	25W	35W
Battery Capacity	3.2V15000mAh	3.2V30000mAh	3.2V45000mAh
Lamp Size	630*242*62mm	806*242*62mm	982*242*62mm
Panel Size	415*200*3mm	660*200*3mm	905*200*3mm
Package	5sets/CTN		
IP Class	IP65		
Charging Time	4-5h		
Working Time	10-20h		
Color Temperature	Cool White (6000-6500K)		



Model No.	FGET-LC30W	FGET-LC40W	FGET-LC50W	FGET-LC60W	FGET-LC90W
Solar Panel Type	Mono Crystalline				
Power of PV Module	60W	70W	80W	90W	125W
PIR Sensor	Yes (PIR/Microwave type, selectable)				
Visual Angle	150°×70°(Optional)				
Light Output	48W	72W	96W	120W	192W
LiFePO4 Battery	250Wh	291Wh	320Wh	384Wh	520Wh
Dimension	900*385*73mm	1060*385*73mm	1210*385*73mm	1390*385*73mm	1805*385*73mm
Main material	Die Casting Aluminum alloy				
LED Clip	MD5050 (Philips, Bridgelux, Cree, Osram, Nichia available and optional)				
Color Temperature	3000-6500K(Optional)				
Charge Controller	MPPT Charging				
Battery Backup Time	2~3 days				
Operating temperature	-20 °C to +75 °C				
Fitting Color	RAL 9006(Optional)				
IP Class	IP66				
Operational life	25 years				
Mounting Bracket	Azimuth: 360° rotation; Inclination angle: 0-90° adjustable				
Application	Residential Areas, Roads, Parking Lots, Suares, Parks, Municipal, Agriculture Lightings & Aquaculture Lightings				
Certificate	Certificate CE, RoHS, CB, IEC60598, IK10, LM79				

FGET 6kW Solar System: Off-grid

Single/Spilt Phase Inverter

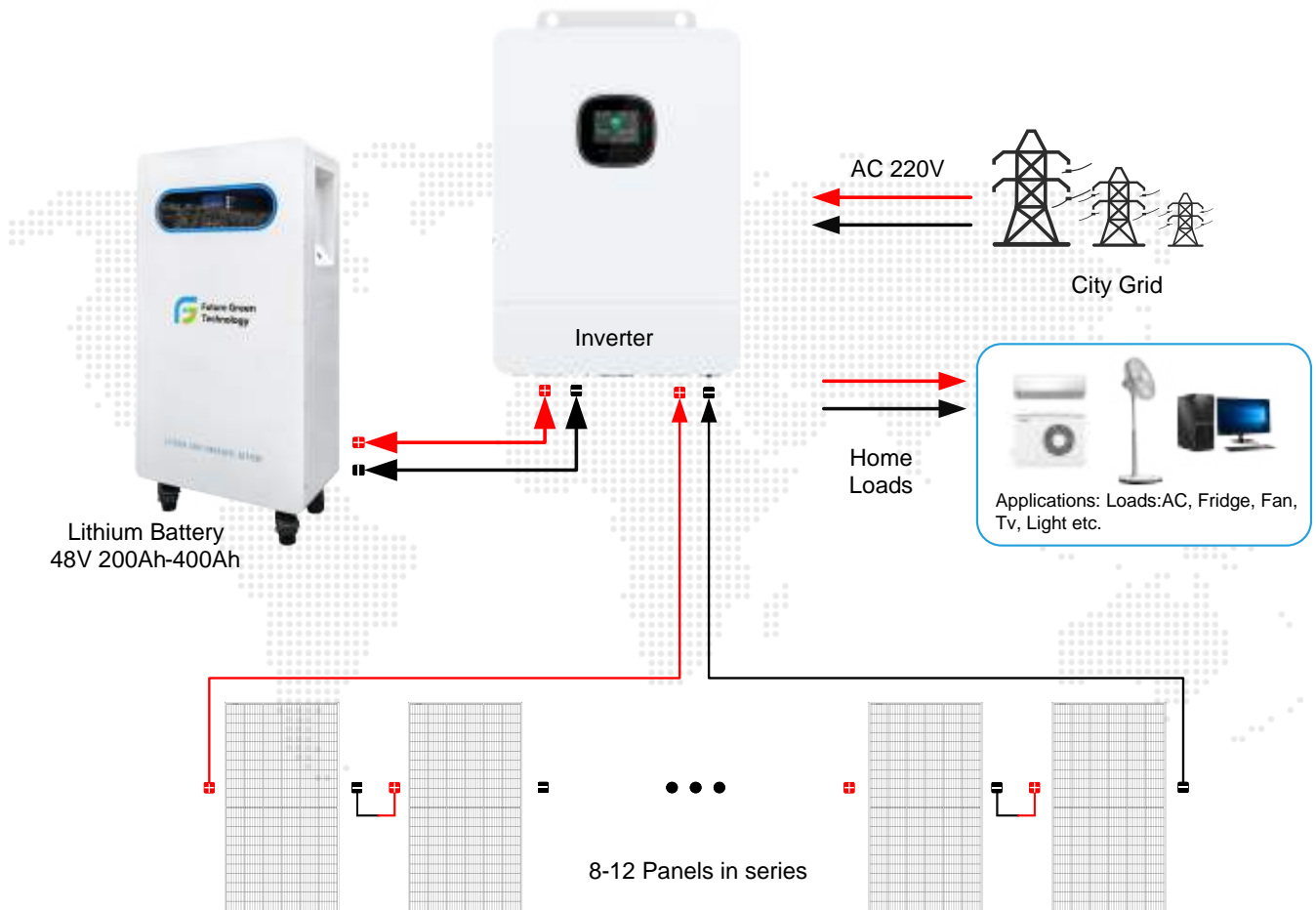

Configuration

Item	Specifications	Quantity
Inverter	48V 6kW Hybrid inverter	1 PCE
Controller	Built-in MPPT 48V 100A; PV500V	1 PCE
Solar Panel	400W-640W Mono solar panels	6-12 PCS
Battery	FGET-48V 200Ah Lithium Battery	1 PCE
Mounting System	Can be customized according to the roof	Optional

FGET 12kW Solar System: Off-grid

Single/Spilt Phase Inverter

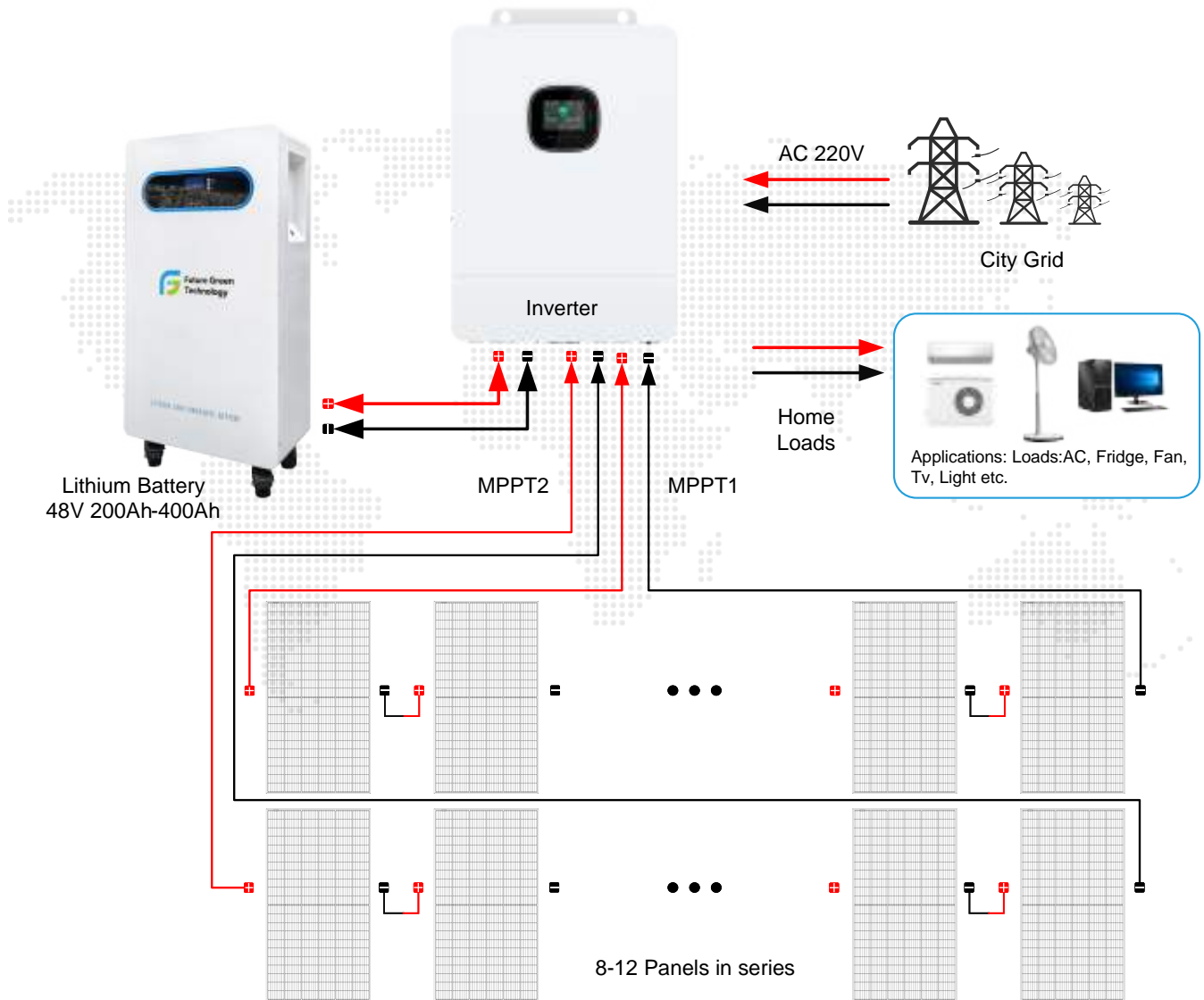

Configuration

Item	Specifications	Quantity
Inverter	FGET-48V 12kW Hybrid inverter	1 PCE
Controller	Built-in MPPT 48V 120A*2; PV500V	1 PCE
Solar Panel	400W-640W Mono solar panels	16-24 PCS
Battery	FGET-48V 300Ah Lithium Battery	1 or more PCS
AC Distribution Box	FGET-N4, Waterproof IP65	1 PCE
Accessory	Cables	1 SET
Mounting System	Can be customized according to the roof	Optional

FGET 20kW Solar System: Off-grid

Parallel Solution

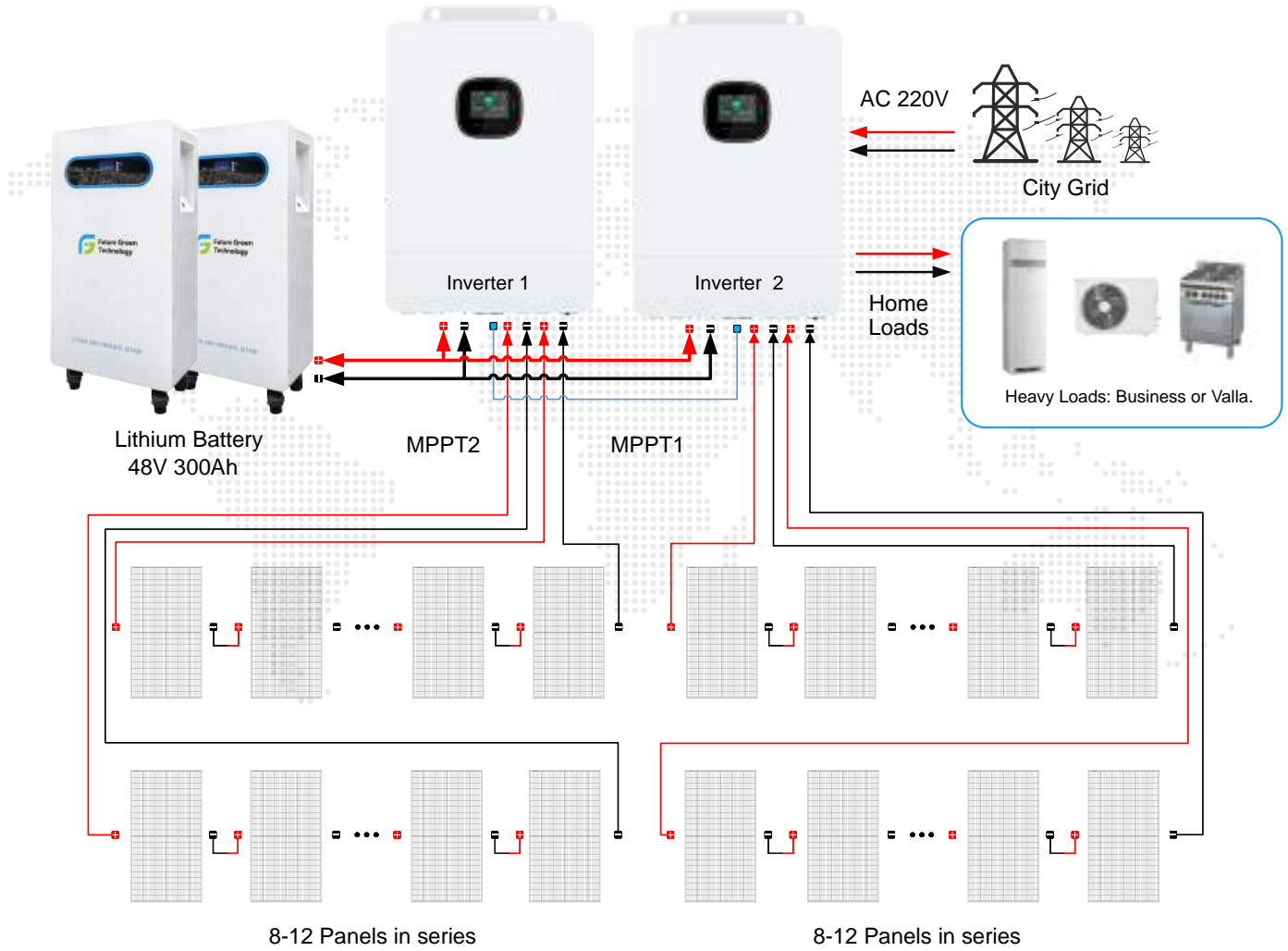

Configuration

Item	Specifications	Quantity
Inverter	FGET-48V 12kW Hybrid Inverter	2 PCS
	Built-in MPPT 48V 120A*2; PV500V	
Solar Panel	400W-640W Mono Solar Panels	32-48 PCS
Battery	FGET-48V 300Ah Lithium Battery	2 or more PCS
AC Distribution Box	FGET-N4, Waterproof IP 65	1 PCE
Accessory	Cables	1 SET
Mounting System	Can be customized according to the roof	Optional

FGET 20kW Solar System: Hybrid

High Voltage Solution

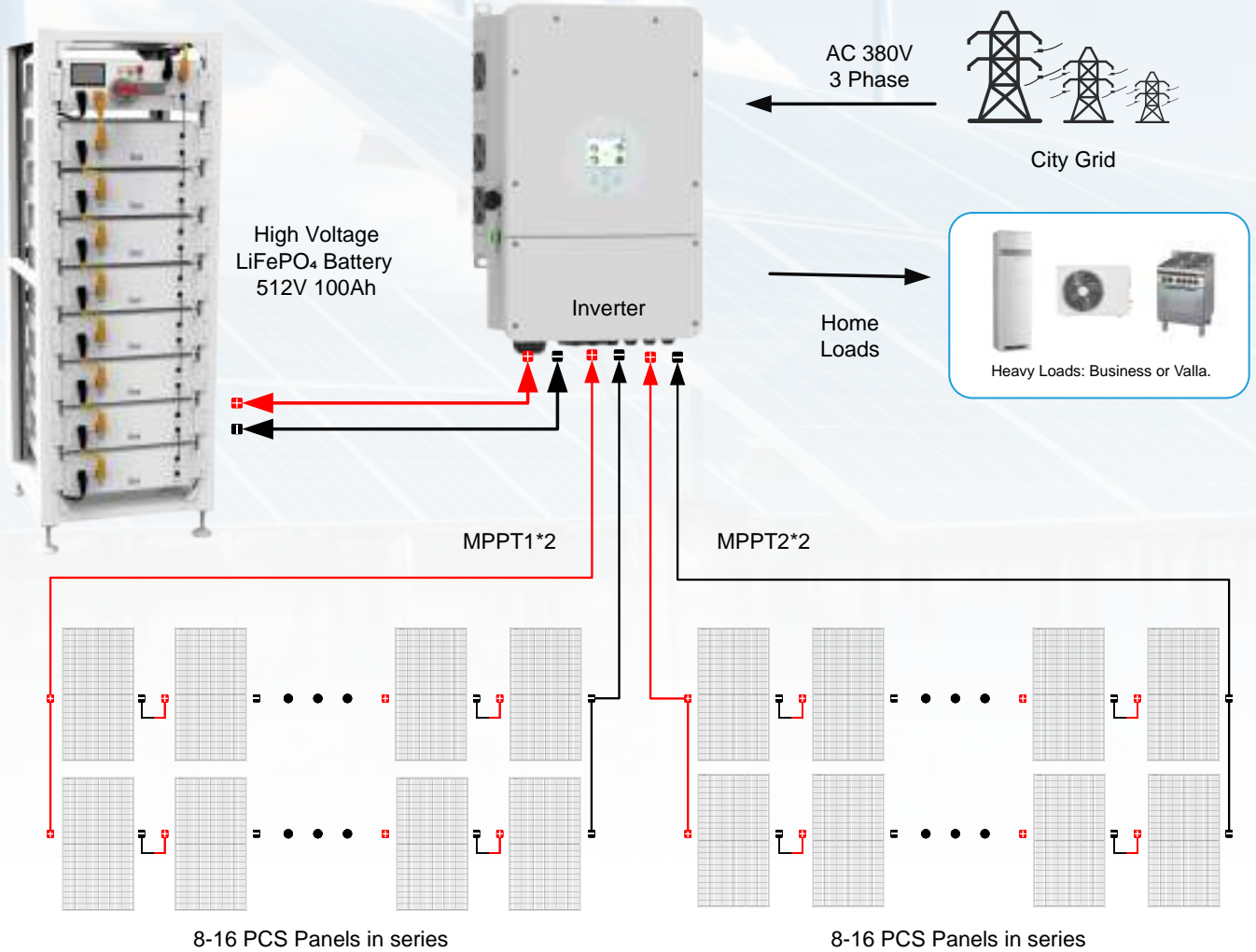

Configuration

Item	Specifications	Quantity
Inverter	Brand Hybrid Inverter SUN-20K-SG01 3 Phase	1 PCE
	Built-in MPPT 26A*2; PV150-850V	1 PCE
Solar Panel	FGET-580W Mono solar panels	24-64 PCS
Battery	FGET-512V 100Ah Lithium Battery	1 PCE
AC Distribution Box	FGET-N4,Waterproof IP65	1 PCE
Accessory	Cables and Accessory	1 SET
Bracket	Can be customized according to the roof	Optional

FGET 100kW Solar System: Hybrid

Energy Storage System

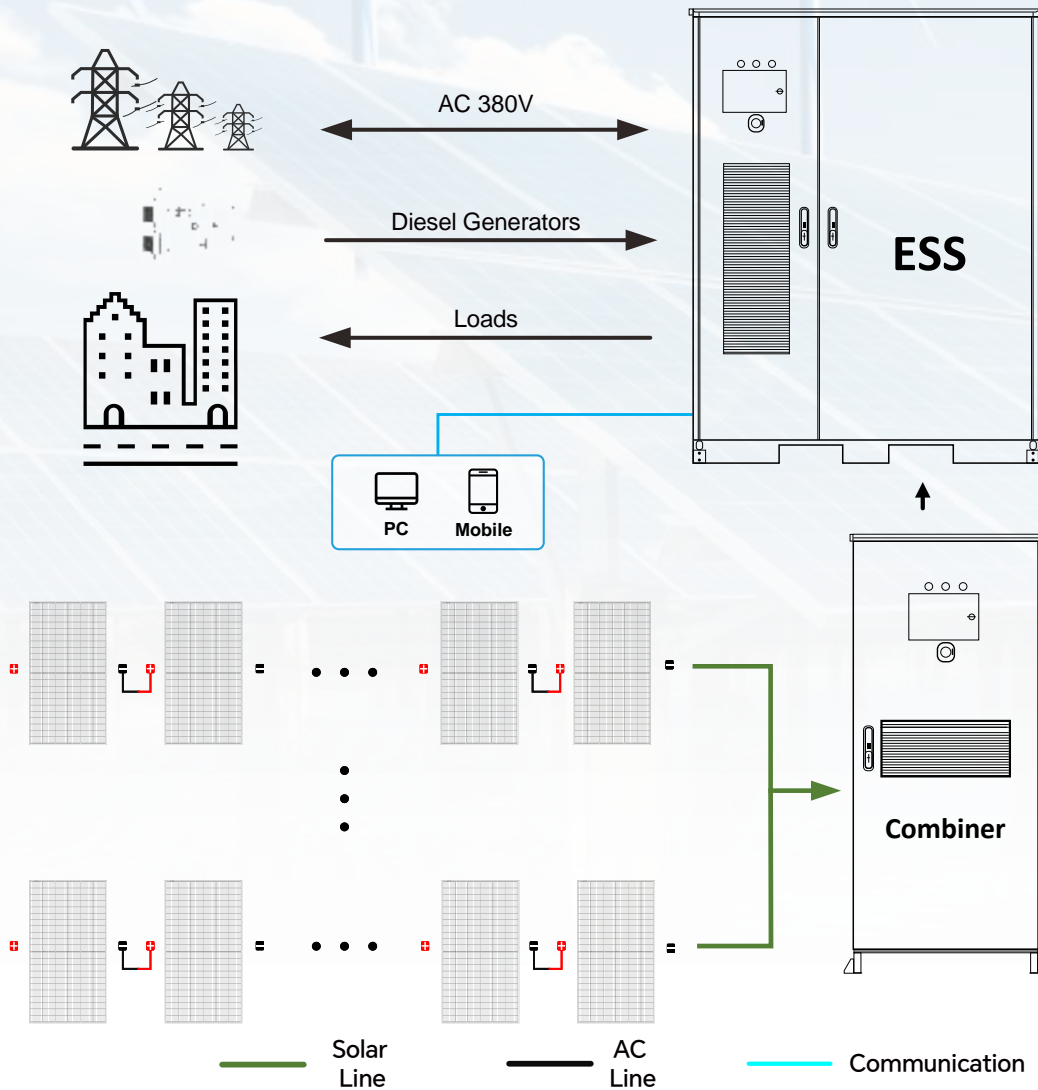

Configuration

Item	Specifications	Quantity
Energy Storage System	FGET-215kWh-100kW3M-HP1	1 PCE
	Battery rated energy	215kWh
	PCS rated power	100kW
Solar Panel	FGET-580W Mono solar panels	180 PCS
Combiner Box	FGET-6 in 1, Waterproof IP65	2 PCS
AC Distribution Box	FGET-N4, Waterproof IP65	1 PCE
Accessory	Cables	1 SET
Mounting System	Can be customized according to the roof	Optional

Solar Balcony System

Insufficient space can also use solar energy:

- 01 High efficiency
- 02 Energy saving
- 03 Environmental protection
- 04 Easy to install

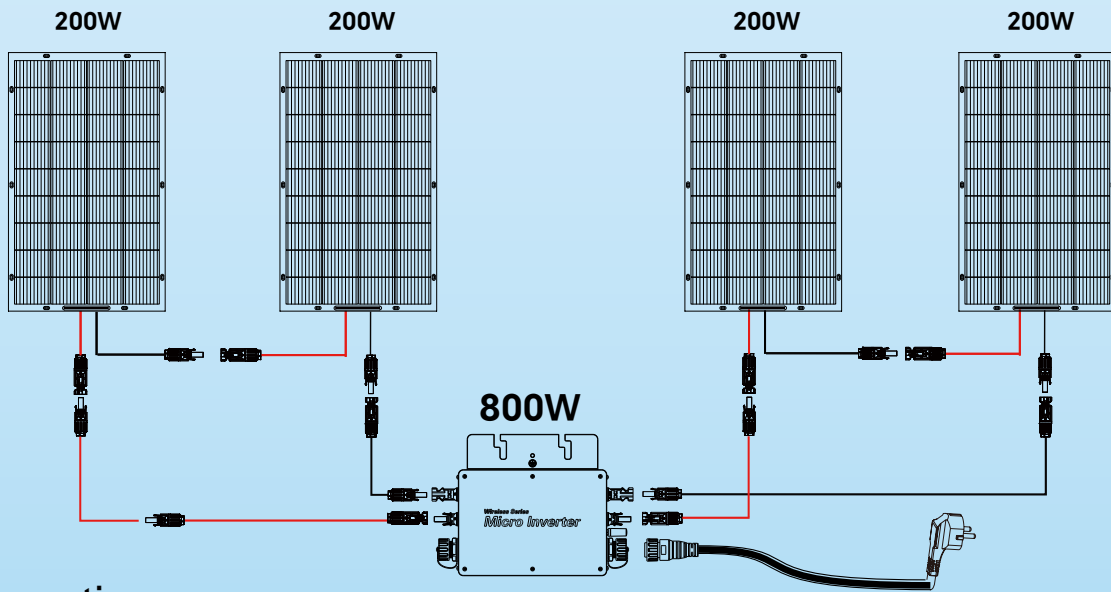

Configuration

Item	Specifications	Quantity
Inverter	800W Micro Inverter	1 PCE
Solar Panel	6*120W Flexible Solar Panels or 2*400W Rigid Solar Panels	1 SET
Extension Cable	2m Extension Cable	1 PCE
Solar Connectors	2 in 1 MC4 Cable Y Branch	2 PAIRS
Mounting System	Reverse buckle magic cable ties or Stainless steel cable ties	50 PCS

Certifications





500kW On-grid and Energy Storage Solar Project on Our Factory



Certifications

3MW On-Grid Solar Project in Qingyuan



50kW Off Grid Non-profit Solar Project in Senegal



5MW On-Grid Solar Project in Shaoguan



200kW Parking Shed Energy Storage Station in Guangzhou



800kW Storage Project in Paluga, Bangladesh



Future Green Technology Co., Ltd.

Mobile/WhatsApp/Wechat

+86 14737539687

Email:

info@futuregreenbattery.com

Web:

www.futuregreenbattery.com

Factory Address:

Yongxing Tongli low-carbon Industrial Park, Longgui Street, Baiyun District, Guangzhou



WhatsApp



WeChat